

# Pumphouse Heater U Series



Stainless shown



**Model Code:**

U	24	10	SS
A	B	C	D

**A: Series**  
**B: 12 - 120V 20- 208V**  
**24 - 240V**  
**C: Watts (1000)**  
**D: -SS Stainless Steel**



Rated for damp locations

- ETL listed for use in damp locations
- Available in textured gray or stainless steel
- Designed to meet requirements outlined in ASSE-1060
- Built-in thermostat with frost protection (40° to 90°F)
- Stainless steel element
- Standard baked enamel protective coating
- Built in mounting bracket
- Convection/Radiant heat
- Vertical or horizontal mount
- 1-year limited warranty



## The U Series Pumphouse Heater

The U Series heater is designed to reduce moisture from mechanical equipment and keep pumps, valves, and farm machinery from freezing. Having the radiant heat absorbed by the metal equipment makes this heater more effective than convection heaters. The built-in thermostat turns off when the ambient temperature is safely above freezing. An optional 304 Stainless Steel (Add-SS to the model number) version helps prevent corrosion associated with high moisture locations like pump houses. A steel guard helps keep foreign objects away from the element. This heater is simple and reliable with no moving parts to wear out or maintain, making it an inexpensive choice for freeze protection. Specifically designed to operate in both vertically and horizontally positions.

### Ordering Information

	MODEL	UPC#	VOLTAGE	WATTAGE	WEIGHT lbs
<b>120V</b>	U2425**	12612	120	62	4
	U2450**	12615	120	125	4
	U2475**	12618	120	187	4
	U24100**	12621	120	250	4
	U1250**	12605	120	500	4
	U1275**	12606	120	750	4
<b>240V</b>	U12100**	12609	120	1000	4
	U2425**	12612	240/208*	250/187	4
	U2450**	12615	240/208*	500/375	4
	U2475**	12618	240/208*	750/563	4
	U24100**	12621	240/208*	1000/750	4

\*\*Add -SS for stainless steel construction

\*Dual rated heaters will draw 13% less amps and 25% less wattage when operated at 208V.

### Dimensional Data

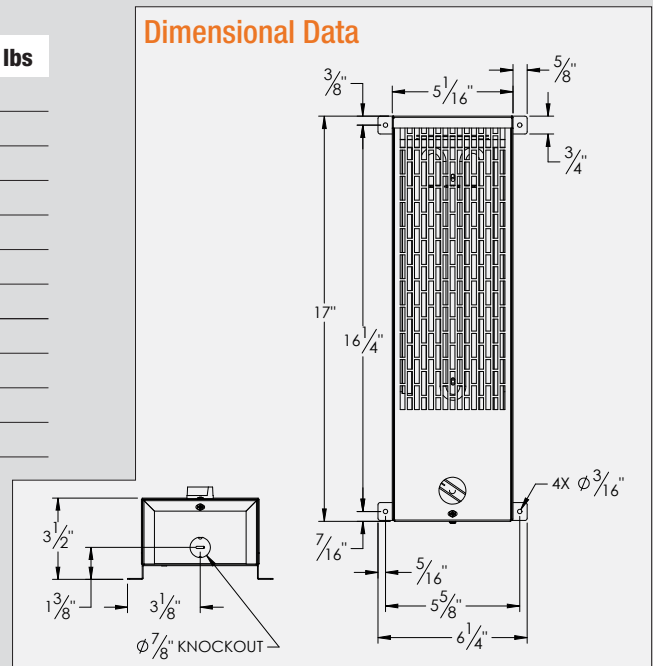

### Engineering Specifications

Contractor shall supply and install U Pump House series radiant heaters manufactured by King Electrical Mfg. Company. Heaters shall be of the wattage and voltage as indicated on the plans.

**Element:** 304 or 840 Stainless Steel.

**Thermostat:** Built-in snap action with a range of 40° to 90°F.

**Safety Limit:** Capillary tube running the full length of the element provides over-temperature protection then automatically resets when temperature drops.

**Enclosure:** Steel case with an expanded steel metal element shield (optional 20 gauge 304 Stainless Steel on -SS model).

**Safety Standard:** cETLus